

## Product datasheet

AFS-30WH

**LED Floodlight with  
sensor | 30 W**

- Closets and cabinets
- Garages and driveways
- Outdoor pathways and walkways
- Porch and patio areas
- Basements and utility rooms



## General information

• Model	AFS-30WH
• LED chip	San`an / SMD2835
• Dimensions	168 x 196 x 50 mm
• Body material	Cast aluminum
• Optical material	Toughened glass
• Top coat	Powder coating
• Environment	Outdoor lighting
• Typical application	Garden, basements, porches, driveways
• Operating temperature	- 40° +50° @10-80 RH
• Mounting	Bracket
• IP protection rate	IP65
• Weight	0.4 kg
• IK protection rate	6
• Warranty	3 years

## Electrical specifications

• Power consumption	30 W
• Input voltage	220-240 Vac / 50-60 Hz
• Surge protection	2 KV
• Power cord	15 CM*1.0 mm <sup>2</sup>

## Lighting specifications

• Luminous flux	2 550 lm
• Luminous efficiency	85 lm/W
• Coverage area	18 400 mm <sup>2</sup>
• Sensor detection	10 m
• Detection range	120°
• CCT	6 500 K
• Color Render Index (CRI)	≥ 80
• Beam Angle (BA)	120°
• Unified Glare Rating (UGR)	≤ 19
• Life span	36 000 h
• DF	0.9

## Photometric diagram

## Packing information

- Size of carton box 171 x 50 x 201 mm

## Dimensions

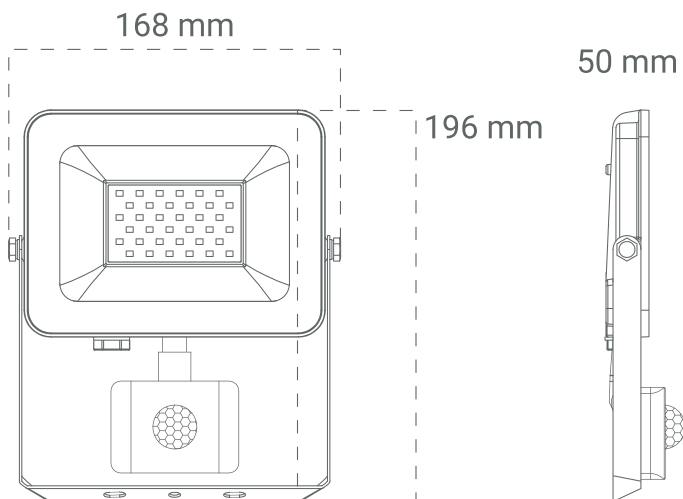

**NET WEIGHT: 400 g**

## Tehnički list proizvoda

AFS-30WH

**LED Reflektor sa  
senzorom | 30 W**

- Ormari
- Garaže i prilazi
- Vanjske staze i šetnice
- Trijemovi i terase
- Podrumi i pomoćne prostorije



## Osnovne informacije

• Model	AFS-30WH
• LED čip	San`an / SMD2835
• Dimenzije	168 x 196 x 50 mm
• Materijal kućišta	Lijevani aluminij
• Optički materijal	Kaljeno staklo
• Završni sloj	Bojanje u prahu
• Ambijent	Vanjska rasvjeta
• Tipična upotreba	Vrt, podrumi, trijemovi, prilazi
• Ambijentalna temperatura	- 40° +50° @10-80 RH
• Montaža	Držač
• IP stopa zaštite	IP65
• Težina	0.4 kg
• IK stopa zaštite	6
• Garancija	3 godine

## Električne specifikacije

• Potrošnja energije	30 W
• Ulazni napon	220-240 Vac / 50-60 Hz
• Zaštita od prenapona	2 KV
• Kabel	15 CM*1.0 mm <sup>2</sup>

## Specifikacije rasvjete

• Svjetlosni tok	2 550 lm
• Svjetlosna učinkovitost	85 lm/W
• Područje pokrivenosti	18 400 mm <sup>2</sup>
• Detekcijski domet senzora	10 m
• Detekcijski kut senzora	120°
• CCT	6 500 K
• Indeks renderiranja boja (CRI)	≥ 80
• Kut svjetlosnog snopa (BA)	120°
• Jedinstvena ocjena odsjaja (UGR)	≤ 19
• Životni vijek	36 000 h
• DF	0.9

## Fotometrijski dijagram

## Informacije o ambalaži

- Dimenzije kartonske ambalaže 171 x 50 x 201 mm

## Dimenzije proizvoda

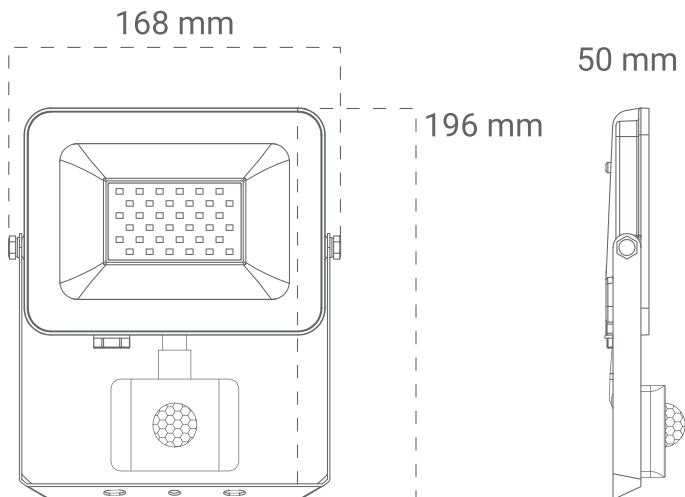

**NET WEIGHT: 400 g**



## Technisches Datenblatt des Produkt

AFS-30WH

**LED-Reflektor mit  
Sensor | 30 W**

- Schränke
- Garagen und Einfahrten
- Wege und Gehwege im Freien
- Veranden und Terrassen
- Keller und Hauswirtschaftsräume



## Grundinformation

• Modell	AFS-30WH
• LED-Chip	San`an / SMD2835
• Maße	168 x 196 x 50 mm
• Gehäusematerial	Aluminiumguss
• Optisches Material	Gehärtetes Glas
• Die letzte Schicht	Pulverbeschichtung
• Umfeld	Außenbeleuchtung
• Typische Verwendung	Garten, Keller, Veranden, Einfahrten
• Umgebungstemperatur	- 40° +50° @10-80 RH
• Montage	Halterung
• IP-Schutzrate	IP65
• Gewicht	0.4 kg
• IR-Schutzrate	6
• Garantie	3 Jahre

## Elektronische Spezifikationen

• Energieverbrauch	30 W
• Eingangsspannung	220-240 Vac / 50-60 Hz
• Überspannungsschutz	2 KV
• Kabel	15 CM*1.0 mm <sup>2</sup>

## Beleuchtungsspezifikationen

• Lichtstrom	2 550 lm
• Lichteffizienz	85 lm/W
• Abdeckungsbereich	18 400 mm <sup>2</sup>
• Erfassungsbereich des Sensor	10 m
• Erfassungswinkel des Sensor	120°
• CCT	6 500 K
• Farbwiedergabeindex (CRI)	≥ 80
• Der Winkel des Lichtstrahls (BA)	120°
• Einzigartige Blendungsbewertung (UGR)	≤ 19
• Lebensdauer	36 000 h
• DF	0.9

## Photometrisches Diagramm

## Verpackungsinformationen

- Abmessungen der Kartonverpackung 171 x 50 x 201 mm

## Produktabmessungen

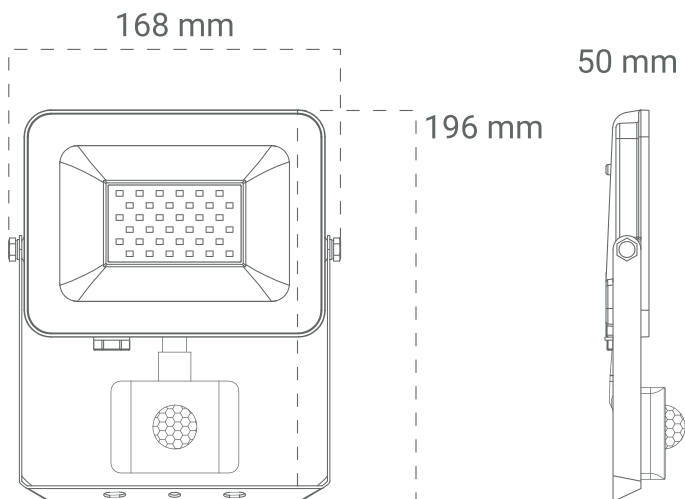

**NET WEIGHT: 400 g**

## Podatkovni list izdelka

AFS-30WH

**LED reflektor s  
senzorjem | 30 W**

- Omare in omarice
- Garaže in dovozne poti
- Zunanje poti in pešpoti
- Verande in terase
- Kleti in pomožni prostori



## Splošne informacije

• Model	AFS-30WH
• LED čip	San`an / SMD2835
• Dimenzije	168 x 196 x 50 mm
• Material puzdra	Liti aluminij
• Optični material	Kaljeno steklo
• Zgornji sloj	Prašni premaz
• Okolica	Zunanja razsvetljava
• Tipična uporaba	Vrt, kleti, verande, dovozne poti
• Delovna temperatura	- 40° +50° @10-80 RH
• Montaža	Nosilec
• Stopnja zaščite IP	IP65
• Teža	0.4 kg
• Stopnja zaščite IK	6
• Garancija	3 leta

## Električne specifikacije

• Poraba energije	30 W
• Vhodna napetost	220-240 Vac / 50-60 Hz
• Zaščita pred prenapetostjo	2 KV
• Napajalni kabel	15 CM*1.0 mm <sup>2</sup>

## Specifikacije razsvetljave

• Svetlobni tok	2 550 lm
• Svetlobni izkoristek	85 lm/W
• Območje pokrivanja	18 400 mm <sup>2</sup>
• Zaznavanje senzorja	10 m
• Območje zaznavanja	120°
• CCT	6 500 K
• Indeks upodabljanja barv (CRI)	≥ 80
• Kot svetlobnega snopa (BA)	120°
• Enotna ocena bleščanja (UGR)	≤ 19
• Življenjska doba	36 000 h
• DF	0.9

## Fotometrični diagram

## Informacije o pakiranju

- Velikost kartonske škatle 171 x 50 x 201 mm

## Dimenzije

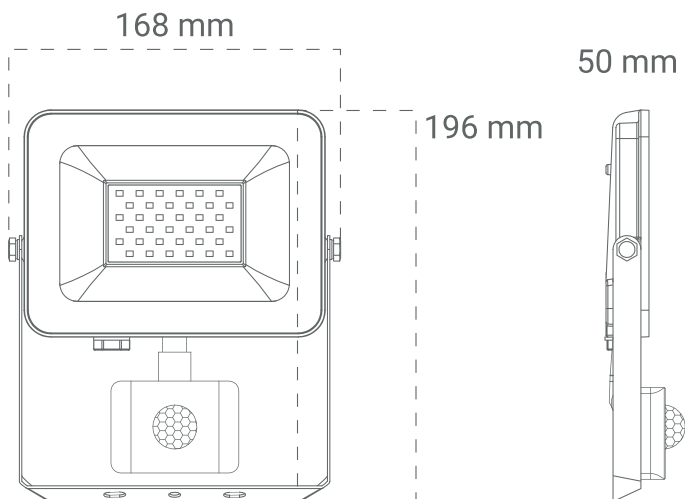

**NET WEIGHT: 400 g**